

**Semester 1
15 Credit Hours**

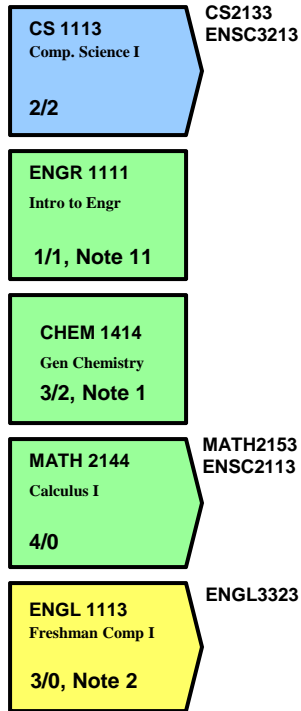

CS2133
ENSC3213

MATH2153
ENSC2113

ENGL3323

**Semester 2
15 Credit Hours**

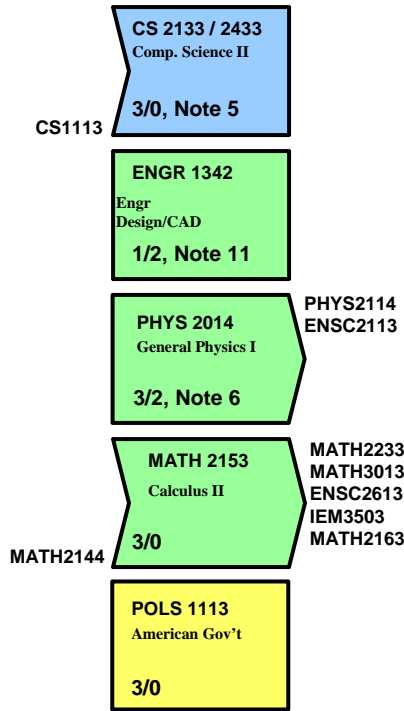

CS1113

PHYS2114
ENSC2113

MATH2233
MATH3013
ENSC2613
IEM3503
MATH2163

MATH2144

**Semester 3
16 Credit Hours**

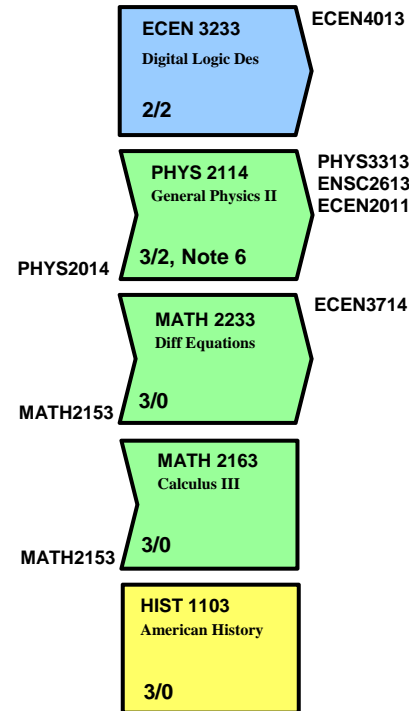

ECEN4013

PHYS2014

MATH2153

MATH2153

PHYS3313
ENSC2613
ECEN2011

ECEN3714

**Semester 4
16 Credit Hours**

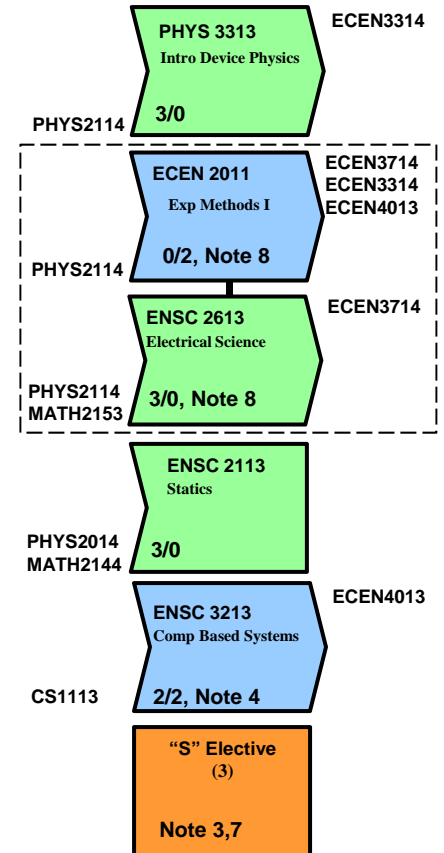

ECEN3314

PHYS2114

PHYS2114

PHYS2114
MATH2153

PHYS2014
MATH2144

ECEN3714
ECEN3314
ECEN4013

ECEN3714

ECEN4013

CS1113

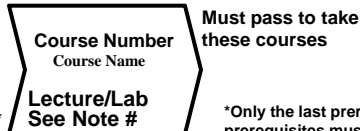

Must pass to take these courses

Prerequisites*

*Only the last prerequisite in a sequence is listed. All earlier prerequisites must also be satisfied before taking the course.

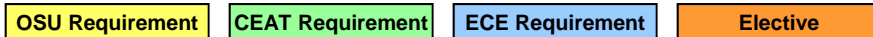

Suggested Course Plan

The anticipation at OSU and most institutions of higher education is that for one semester credit hour (SCH) the student spends one hour per week in lecture (two for lab courses) and two hours studying outside of class (one for lab courses). A three credit hour class requires, on average, about nine hours per week. This study plan is recommended for students who will devote full time to university studies and do not have excessive extracurricular activities or other obligations.

NOTES:

- 1) Chemistry 1515 may be substituted for CHEM 1414 and should be taken by all students considering medical school.
- 2) Students with less than a "B" in ENGL 1113 or 1313 must take ENGL 1213 or 1413 prior to ENGL 3323.
- 3) A total of at least 6 hours designated "H" and 6 hours designated "S" are required. Of these, 3 hrs must meet the International Dimension "I" component and 3 hrs must meet the Diversity "D" component.
- 4) Either ECEN 3213 (no longer offered) or ENSC 3213 (beginning Fall 2008) is acceptable.
- 5) CS 2433 may be taken instead of CS 2133.
- 6) General Physics I and II are key prerequisites and should be taken at the earliest possible time.
- 7) Must be at least 3 SCH.
- 8) The line indicates this course has a co-requisite and must be taken together.
- 9) Must be approved by ECE advisor and satisfy current (2010-11) Area of Specialization requirements.
- 10) Should be chosen from ECEN 3113, 3613, 3723, and 3913, not taken elsewhere.
- 11) ENGR 1113 may be substituted for ENGR 1111 and ENGR 1342 with permission.

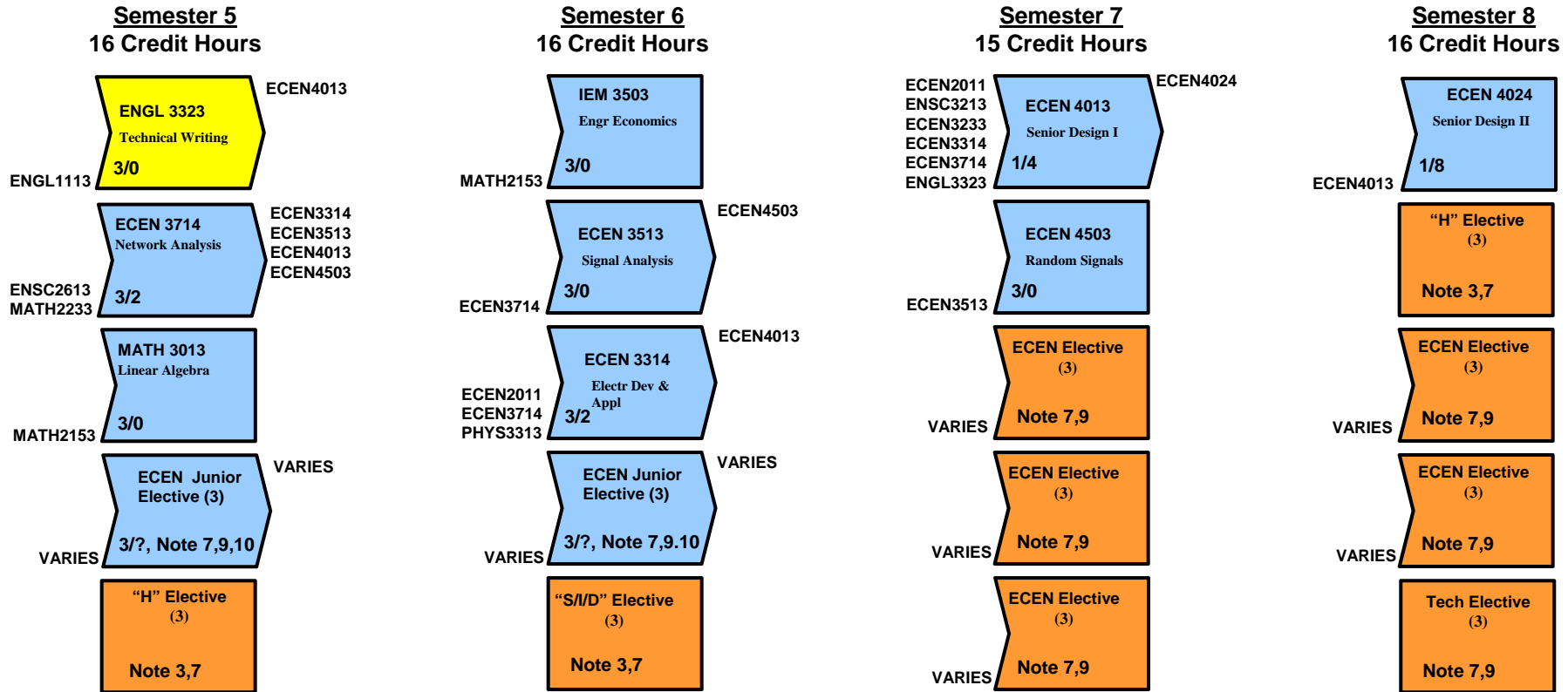

Professional School Entry Requirements:

- Completion of at least 60 college level semester credit hours (SCH).
- Completion of at least 12 SCH from OSU.
- Completion of MATH 2144, 2153, 2163, 2233; PHYS 2014 and 2114; CHEM 1414; ENGR 1111, 1342; ENSC 2113, 2613, 3213 (beginning fall 2008); ECEN 2011, 3233; ENGL 1113 or 1313; CS 1113, 2133 or 2433.
- A grade of "C" or better in each of those courses listed above.
- An overall GPA of 2.6 or better at OSU.
- A GPA of 2.7, or better, in all of the college-level math, science and engineering courses required for the B.S. in Electrical Engineering.

•**This flowchart is only an advising instrument.** When conflicts occur, the official 2011-2012 Degree Requirement Sheet takes precedence. Always check for the most current version of this flowchart.

•**Admission to Professional School is required to take upper level ECEN-prefix courses.** Please refer to the OSU Catalog corresponding to your matriculation date for detailed admission requirements.

